

Techtonic Non - Retractable

External louvre blinds for
shaped and sloping glazing

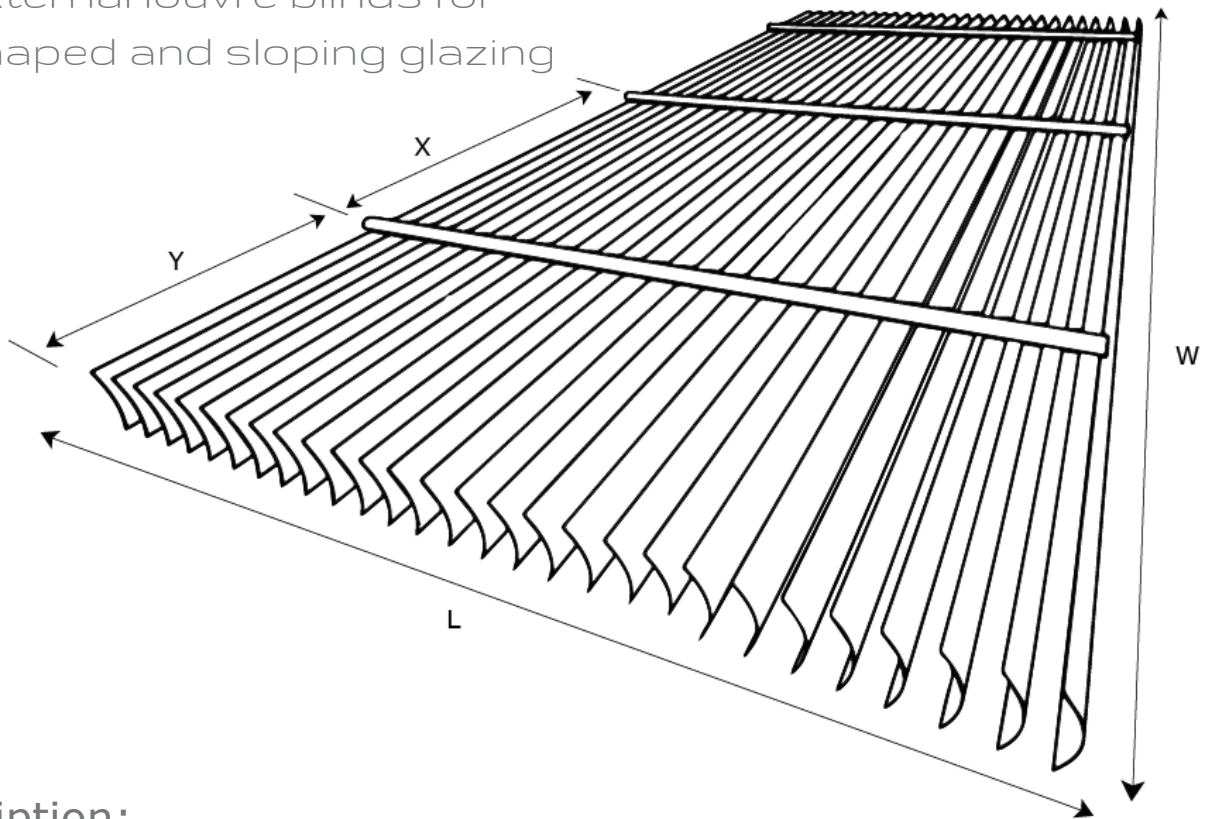

Description:

The Techtonic range of non retractable blinds are the most appropriate blinds for roof lights and sloping glazing areas, in particular, a conservatory roof. The slatting is supported from aluminium rack arms to prevent sagging that could occur with retractable blinds. It can also be installed vertically and can be made to fit almost any type of window. It can be cut around obstructions such as fans or window winders.

For internal blinds it is available with 50mm aluminium or timber slat. More robust 80mm and 88mm louvres are suitable for internal or external use and the 88mm louvre also achieves a good degree of dim out for audio visual applications in lecture halls.



T50 timber



T80 Aluminium



T50 Aluminium



T88AV Extruded Aluminium

All to scale 1:1

Louvre types

T50 - Flexible slat 50mm wide, the standard for internal blinds, stove enamelled in an extensive range of colours.

T50W - Kiln dried American Basswood laths 50mm x 3mm in natural and a range of stained finishes.

T80 and T80X - Roll formed aluminium louvres with beaded edges for internal or external applications.

T88AV and T88XAV - An extruded aluminium section that is natural anodised AA25 or polyester powder coated. It neatly interlocks to provide closure for audio visual applications. The blind is ideal for lecture halls and provides a high level of dim-out for film projection. The blind can be fitted internally or externally.

Louvre Carriers - The standard rack arm assembly has an aluminium T-Bar section, 35mm x 20mm fitted with pivot-able nylon slat clips which are linked to a 12mm x 3mm aluminium operating bar. When used externally, all aluminium components are anodised AA25 or powder coated.

Slat Clips - A moulded nylon clip secures the slats whilst allowing easy removal for cleaning and maintenance. The design of the clip prevents scratching of the slats whilst allowing complete closure.

Tilt Shaft - A hexagonal aluminium extrusion that is sufficiently rigid to reduce torque to a minimum. A nylon coupling moulding is available to link adjacent blinds to the same operating mechanism.

Fixings - Nylon mouldings or aluminium cleats locate into the rack arms and are fitted with 6mm stainless steel studding for ease of alignment. All fixing brackets are aluminium.

Slat spring A stainless steel clip that is used on T80 external blinds and is fitted across the top of the slat and locates in the nylon slat clip.

Cross support - Aluminium channel section (33 x 21mm) that spans across the glazing bars where a fixing point is not otherwise available.

Methods of control - The louvres rotate through 125° from the closed position by various control options that turn the tilt shaft, this turns a nylon cam moulding which draws the operating bar that is linked to a pin in the end of the slat clips.

Lever - For smaller blinds where it is possible to reach the tilt shaft, a nylon lever is fitted to the shaft.

Gear operated - A gearbox is fitted to the tilt shaft and is turned by a detachable cranked rod suitable for large and high level blinds.

Motorised operational- A tubular motor drives a gearbox that is connected to the tilt shaft. This is most suited to blinds where access is difficult and group control is required either manually coupling adjacent blinds or linking electrically with relays to one switch. The motor requires a current of less than one amp from a 240v single phase supply.

Photo Voltaic- Techtonic PV comes with an in-built radio receiver that can be activated remotely by a battery operated wall switch or hand held controller.

Automated Control -A central control utilising solar sensors to open and close the louvres at selected external light levels can link several banks of blinds through relays to ensure uniform operation. A more sophisticated 3 lux level system allows adjustment of the louvre angle to achieve a pre-determined lux range. (See automated control leaflet.)

Time Control - A central control can utilise a timer to operate the blinds at chosen times, this can also be incorporated with a solar sensor system.

Specification sheet

Design Considerations

a) To allow for the rack arm and support structure, the centre line of slats is a minimum of 120mm from the fixing point (dia.ii) this dimension can be increased by extending the bracket studding but cannot be reduced. Aesthetically, it may be desirable to align rack arms with the glazing bar this may increase the number of racks needed.

b) Adjacent blinds can have the slatting areas linked to operate as one by coupling the tilt shafts, if the maximum sq. area is not exceeded.

c) With woodslat blinds we do not recommend more than three rack arms for each slatting area. Larger openings should be divided into slatting areas, and these coupled at the tilt shaft.

d) The rack arms can be mounted to operate the blinds in two ways (see dia. iii & iv). The standard mounting (iii) will allow a more gradual increase in light levels from the closed position.

e) The rack arm, in the horizontal position, will normally run North to South.

f) A lever control will operate small blinds. Areas over 8 sq. m will need gearbox or electric operation.

g) Where the drop of the blind is over 2.5 metres, and an intermediate fixing point is not available, cross support must be used.

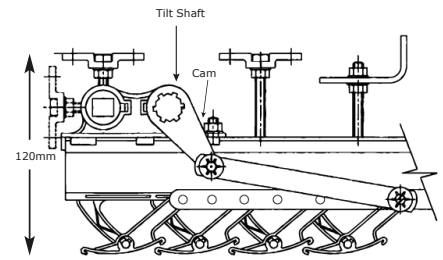

T50 Rack Arm
Diagram ii

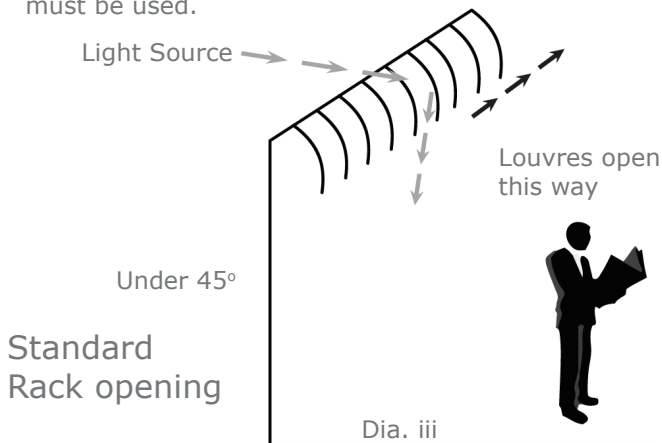

Standard
Rack opening

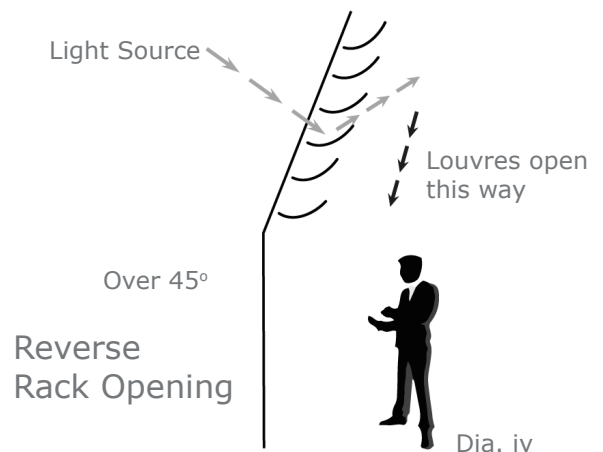

Reverse
Rack Opening

Design tolerances are different for each slat size as shown on the dimension table below

Slat type	T50W	T50	T80	T88AV	T80X	T88X
Max. Slat overhang (Y)	300	400	500	150	250	150
Max. Distance between rack arms (X)	750	900	1400	1500	1000	1200
Max. Blind width slat length (W)	1750	6000	5000	4000	5000	4000
Max sq. metre lever control	8m ²	8m ²	8m ²	-	8m ²	-
Max sq. metre gear/ electric	20m ²	20m ²	20m ²	16m ²	20m ²	12m ²
Max. Width 2 rack arms	1250	1700	2400	1800	1500	1500
Max. Width 3 rack arms	1750	2600	3800	3300	2500	2700
Max. Width 4 rack arms	-	3500	5000	4000	3500	3900
Max. Width each extra rack arms	-	900	-	-	1000	-
Slat pitch	45	45	70	70	70	70
No. Slat per metre rack (rounded down)	22.5	22.5	14.3	14.3	14.3	14.3
Max length rack arm length (L)	6000	6000	6000	4000	6000	4000
Max length unsupported rack	2500	2500	2500	2000	2000	1500

Triangles, Arches & Circles

These shapes are operated in the same way as normal openings, except that additional support is required for the slat overhang. This is provided by slave or dummy rack arms. The maximum overhang for each slat type is shown on the Dimension Chart on Page 3 and where this is exceeded, a slave arm will be required. A slave rack does not have an operating strip nor is it connected to the drive shaft. It is only used to support the slat which is turned by the adjacent rack. The end of the slave arm is supported by a cross support bar that spans the adjacent rack.

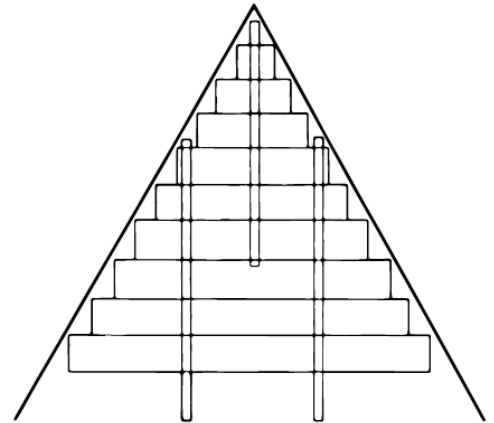

Diagram v

Cut Outs

Where the cut out creates a slat overhang from the rack arm that is larger than the maximum shown on the Dimension Chart, additional rack arms will be needed. This can occur where the blind area is obstructed by window control gear, pipes, cross beams etc. On long drop blinds where small cut outs are required it will be more cost effective to fit a slave arm to cross support channels that are fitted to the racks either side of the cutout (see diagram vi)

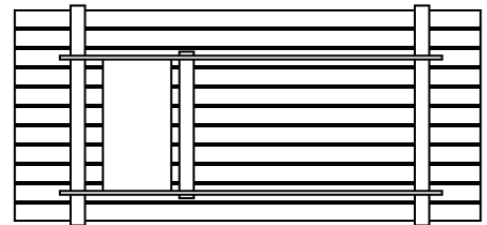

Diagram vi

Curved Fronts

A feature often used on conservatories is for the front part of sloping glazing to be curved (dia.vii) Non-retractable blinds are the only practical method of shading and the effect is achieved by forming the rack arm to the shape of the glazing bars.

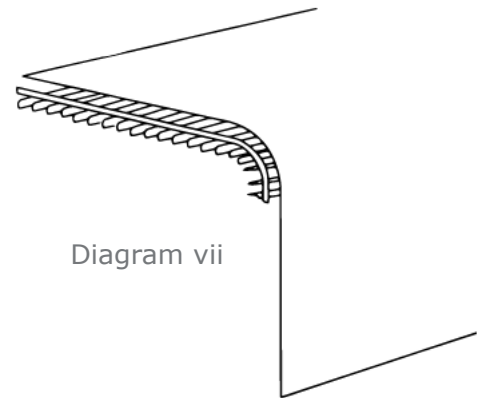

Diagram vii

External Blind Wind baffles

We recommend that a 130 x 50mm aluminium channel section is fitted all round the edges of the blind. This is fitted on the glazing bars and minimises air flow between the blind and glazing.

Audio Visual Masking

Across the width an aluminium angle is fitted top and bottom so that the Iouvres close to them. At the sides a channel with brush strip section is used. (Dia. viii)

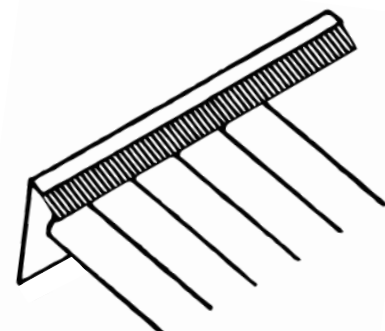

Diagram viii